

BTECH *Battery Validation System*



MODEL BVS-S3D OPERATION MANUAL

BATTERY VALIDATION SYSTEM

BVS S3D XXX

OPERATION MANUAL

Contents

Chapter 1	<i>Turning the System On</i>	1
Chapter 2	<i>Checking System Settings</i>	3
Chapter 3	<i>Changing System Settings</i>	4
	LOCATION CODE NUMBER (C)	4
	DIAL OUT PHONE NUMBER (D)	4
	CURRENT DATE-TIME (0)	5
	NEXT AUTO READ DATE-TIME (1)	5
	AUTO READ INTERVAL (2)	5
	BATTERY UPPER (OR LOWER) VOLTAGE LIMIT (3 OR 4)	6
	UNIT UPPER (OR LOWER) VOLTAGE LIMIT (6 OR 7)	6
	CELL UPPER Ω LIMIT (8)	6
	LEARN INITIAL UNIT IMPEDANCES (9)	7
	PRINT LAST AUTO READ DATA (*)	7
	EXIT TO NORMAL MODE (#)	7
Chapter 4	<i>Clearing Memory</i>	8
Chapter 5	<i>Using the Diagnostic Mode</i>	9
	Setting the Calendar for the Year	9
	Measuring Individual Parameters	9
	Determining Impedance Multipliers	10
Chapter 6	<i>Using the Calibration Mode</i>	11
	Setting Impedance Multipliers (1) (2) (3)	11
	Setting the Load Current Multiplier (4)	12
	Setting the Power Outage Test Interval (5)	12
	Setting the Short Hit Alarm Function (6)	12
	Setting the Temperature Scale (7)	13
	Setting the Alarm Re-send Interval (8)	13
	Confirming the Settings (*)	13

Chapter 7 <i>Collecting & Analyzing Battery Validation System Data</i>	14
Normal Mode Measurement Data	14
Trending the Data	15
Identifying an Impedance Problem	16
Locating an Impedance Problem	16
Power Outage Data	17
Alarms	19
Chapter 8 <i>Significance of Lamp Indicators</i>	20
Chapter 9 <i>Significance of Failure Messages</i>	22
Chapter 10 <i>Customer Support</i>	27
User Replaceable Spare Parts	27
Technical Support	27
Product Warranty	29
BVS S3 Front Panel	30
BVS S3 System Diagram	31
Internal Connector Locations	32
Replacing NiCad Batteries	33

Chapter 1 Turning the System On

When all wiring is complete and fastened in place, the system is ready to be started. First, double-check that the load current connector(s) is (are) out of its (their) socket(s), the **NICAD** switch is **OFF**, and the **RUN/STANDBY** switch is in the **STANDBY** position. Then plug the isolation transformer into the 120 volt, 60 Hz outlet and insert the power connector into the receptacle on the connector panel. The system should respond with an immediate beep. If it does not, unplug the AC and reconnect it within 2 seconds; the boot process should now complete itself promptly and show the time within about 30 seconds.ⁱ The **NICAD** switch disables the internal battery only. Since the system will revert automatically to its own back-up battery when the AC power fails, this switch prevents operation from the battery during shipping and servicing. Turn the **NICAD** switch to **ON**. Also place the **RUN/STANDBY** switch in the **RUN** position.

IMPORTANT: The function of the **RUN/STANDBY** switch is to prevent the closure of all of the relays which connect the battery to the **BVS**. Place this switch in the **STANDBY** position whenever the battery is being serviced to protect personnel and equipment.

Press the * key momentarily and listen for the acknowledging "beep". During the first set of readings following the initial power-up, the system will determine the sequence of cells and long interconnects in the battery. If the quantity of cells or units is correct, the configuration will be stored in memory. The display will confirm the fact by showing the total number of cells or units under **UNIT** in the display window, and the printer will show BVS FOUND XXX UNITS. If the quantity of cells or units is incorrect, the printer will show WRONG AMOUNT OF UNITS - BVS FOUND YYY UNITS - THIS SYSTEM MUST HAVE XXX UNITS - CHECK AB-BC. You must take action to correct the problem before proceeding.

A wiring error or a missing or blown fuse in one of the voltage sense leads will result in the **BVS** detecting fewer cells or units than the battery actually contains. Several courses of action are possible. You may physically check a fuseholder to make sure it contains a good 1/16th ampere fuse (very difficult visually, better to measure resistance, $\approx 30\Omega$). Start with the numbered fuseholder common to the "check" suggested on the printer tape. Or you may measure the voltage between pairs of screw terminals on the 16 and 17-pin connectors. Except where there are long interconnects (which read 0 Vdc), all readings should be nearly the same, i.e. $\approx 2.25\text{Vdc}$, or $\approx 4.5\text{Vdc}$, or $\approx 6.75\text{Vdc}$ or $\approx 13.5\text{Vdc}$. Or, you may use a special diagnostic feature of the **BVS** whereby it will output the voltage it finds between every pair of leads. To engage this mode, set the **BATTERY UPPER VOLTAGE LIMIT** to **000**, then press the * key. When **BVS** finds two "0" readings in a row, it will stop. The lead common to these two "0" readings is open - bad fuse or fuse contact, broken lead, terminal crimped on the wire insulation, are possible causes. After attempting a fix, press the * key again. If the printout is still

ⁱ If the Ram backup battery has become completely discharged, or has been disconnected coincident with replacement of the program EPROM, a time format (xx:xx) may appear but some of the 7-segment characters may not be recognizable as any of the ten Arabic numerals. Simply enter the correct date and time as described on page 6.

incorrect, follow the above procedures to solve all of the wiring problems. When the printout matches the battery configuration, change the **BATTERY UPPER VOLTAGE LIMIT** to its original value or clear the main memory as described in chapter 4 and press the * key again. The **BVS** will then learn the correct battery configuration and indicate that on the display and printer. This configuration will be stored and can only be changed by clearing the main memory or disconnecting or discharging the RAM backup battery.

Occasionally, a **BVS** must be wired in a way that ½ the usual unit voltage appears between sense leads. This situation is normal for these special systems, where such lead pairs are treated by the **BVS** as long interconnects.

After the **BVS** has reported the correct number of cells or units, initiate a measurement sequence by pressing the * key. The printer will output the location number, the date and time, and then the cell or unit voltages, the total voltage, the cell or unit impedances, and the temperatures. Check the voltages carefully. If measuring individual cells, all the readings should be approximately 2.2 volts. Some readings of 4.4 or 6.6 volts indicate voltage sense leads out of sequence. These errors must be corrected before proceeding. If re-ordering the sequence involves those leads attached to long interconnects, it will be necessary to erase the battery configuration just determined. Follow the procedure in Chapter 4, under Clear the Main Memory; then press the * key to redetermine the configuration. Otherwise, if all the changes were within one tier, simply press the * key to start another measurement and confirm that the changes corrected the problem.

Since the load current connector(s) is (are) still out of its (their) sockets, the **BVS** cannot draw a load current from the battery in order to measure impedance. Therefore, at this time the impedance readings should be essentially zero (.00 - .03). The printer tape should confirm this.

Next, using the procedures described in Chapters 2 & 3, make any entries or changes in system settings, such as location code, date, time, alarm limits, and phone number.

Once the system is performing correctly, check that the actual battery voltage is between the upper and lower alarm limits. If it is, initiate a complete measurement by programming a **NEXT AUTO READ DATE-TIME** a few minutes in the future. Insert the load current connector(s) into their respective sockets. If the total voltage is not within limits or the system has been on "equalize", wait until the battery has stabilized for at least two days at the *normal* float voltage before impedance values will be meaningful.

Chapter 2 Checking System Settings

The keyboard buttons have different functions depending on which operational mode is engaged (see **KEYBOARD CODES** on the front panel). The **NORMAL MODE**, in addition to permitting normal unattended operation, allows an operator to check (but not change) settings, print certain data and start or stop a measurement sequence. For instance, if the **C** key is pressed, the display will show the location code that identifies this battery. Likewise, if the **0** key is pressed, the display will show the date and then the time in 24 hour format. If the **3** key is pressed, the display will show the maximum battery voltage allowed before an alarm will be registered.

Four types of information can be printed in the **NORMAL MODE**. When the **A** key is pressed, the contents of the power outage memory will be printed, including unit and battery voltages (and discharge currents if this option has been purchased) and the beginning and ending times of power outages. If the memory is empty, a “boop” tone will be heard. If initial unit impedances have been measured previously, they can be printed by pressing the **9** key. If they have not been measured, a “boop” tone will be heard. When the ***** key is pressed, the system will begin a complete measurement routine, printing the data as it is measured; however, if an alarm has been registered, the reason for the alarm will be printed instead. First, you must clear the alarm before a measurement cycle can be initiated. Pressing the **#** key will clear the alarm; the same key will also abort a manually initiated measurement cycle when you don’t want to continue.

A quick reference card is attached inside the enclosure door. It summarizes the most frequently used keypad operations, described in *Chapters 2 & 3*.

Chapter 3 Changing System Settings

To protect the user from unauthorized changes to system settings, a four-digit “password” must be entered before any changes can be made to the operating program. See **UNLOCKED MODE** under **KEYBOARD CODES** on the front panel. First press the **B** key, and then the four-digit password, listening for the “beep” after each keystroke. The display will not show the password, but acceptance of it will be indicated by the appearance of the **uuu** symbol. If the entered number is not correct for this system, the **uuu** will not appear and the display will return to the way it was before the **B** key was pressed.

It is recommended to write down the settings and limits to be entered so that all the changes can be accomplished at one time. Then unlock the system with the password and change each of the settings. Finally, re-lock the system by pressing **#**, whereupon the **uuu** will disappear and the value shown will be the total battery voltage or the time, depending on which was being displayed before the password was entered.

During any particular entry, a pause longer than 10 seconds will cause the system to assume that the change will not be completed, so do not delay unnecessarily in the midst of a series of keystrokes. On the other hand, if you make a mistake by pressing the wrong key, just wait until the partial entry goes away and then begin again.

If the system is “unlocked” for more than four minutes without a keypad entry, it will re-lock itself automatically to prevent remaining out of the normal measurement mode indefinitely.

LOCATION CODE NUMBER (C)

Press the **C** key; then enter any combination of three digits to identify this particular battery. For example, enter **001** for Location 1. This will be reported as **LOCATION CODE 1**. If the DOS version of the **BVM** software is being used, please note that the corresponding location identifier in **BVM** will be **1 blank blank**, or simply a **1** in the left position.

DIAL OUT PHONE NUMBER (D)

If the system is equipped with a telephone modem, and you want the **BVS** to transmit alarms to a remote PC via a telephone line, you must enter the phone number to dial. Press the **D** key; then enter the number to be called, up to twelve digits including the 1 and area code, if required. Press the **D** key again to signify that the entry is complete. A pause to wait for a second dial tone is automatically provided after the first number, for example, 9, pause, 19735551212. A **DIAL OUT PHONE NUMBER** may be cancelled by pressing the **D** key twice, with no phone number in between.

Entering a dial-out number causes the modem to be initialized. If done remotely, the system will terminate the communications session and then initialize the modem.

CURRENT DATE-TIME (0)

The clock should be running when the system is delivered. If you need to reset it for a different time zone or for Daylight Saving Time, for instance, first press the **0** key. Then enter the month using two digits, as in **02** for February, then the day, again using two digits. Then enter the correct time in 24 hour format, i.e. **0200** for 2 AM. Even if only the time has to be changed, both date and the time must be entered, because the system will memorize eight digits in the date-time format only. If all eight digits are not entered, the number in memory will not be changed, just as if nothing was entered.

NEXT AUTO READ DATE-TIME (1)

Press the **1** key followed by eight digits in the same format as in the step above. For example, if the system is to take the first automatic reading at midnight on July 4th, enter **07040000**. (Time 0000 belongs to the new day.)

AUTO READ INTERVAL (2)

The default **AUTO READ INTERVAL** is 7 days. If this interval is not satisfactory, press the **2** key followed by a new interval in days (i.e. **05**). If the system is to read every two weeks at the same hour, enter **14**. **BTECH** suggests that a set of readings every one or two weeks is adequate. Measurements made more often tend to obscure meaningful data drifts which occur over a long period of time, and accumulate an enormous quantity of data through the years, requiring a large amount of archiving space on the computer's hard disk.

In some applications, it may be desirable to read only when interrogated by the remote host computer. In this case, program **00** as the read interval. Then the system will never cycle through its complete set of readings unless triggered locally by the * key or remotely by the host computer.

READ INTERVAL TABLE

Interval of:	Enter:	Interval of:	Enter:
1 Day	01	2 Weeks + 2 Days	16
2 Days	02	2 Weeks + 3 Days	17
3 Days	03	2 Weeks + 4 Days	18
4 Days	04	2 Weeks + 5 Days	19
5 Days	05	2 Weeks + 6 Days	20
6 Days	06	3 Weeks	21
1 Week	07	3 Weeks + 1 Day	22
1 Week + 1 Day	08	3 Weeks + 2 Days	23
1 Week + 2 Days	09	3 Weeks + 3 Days	24
1 Week + 3 Days	10	3 Weeks + 4 Days	25
1 Week + 4 Days	11	3 Weeks + 5 Days	26
1 Week + 5 Days	12	3 Weeks + 6 Days	27
1 Week + 6 Days	13	4 Weeks	28
2 Weeks	14	4 Weeks + 1 Day	29
2 Weeks + 1 Day	15	≈ Monthly	30

BATTERY UPPER (or LOWER) VOLTAGE LIMIT (3 or 4)

These are the terminal voltages between which the charger is expected to keep the battery while it is on float. Although default limits based on the battery manufacturer's recommended vpc tolerance have been put into the EPROM, changes can be made to suit specific conditions. Press the **3** or **4** key and then enter a three-digit number. If the voltage is less than 100 volts, enter a 0 first as **095** for 95 volts. No decimal point can be entered.

UNIT UPPER (or LOWER) VOLTAGE LIMIT (6 or 7)

These are the individual cell (or unit) limits that are expected while the charger is functioning normally. First, press the **6** or **7** key followed by four digits, as **0210** for 2.10 volts. A decimal point is inserted automatically after the second digit.

CELL UPPER Ω LIMIT (8)

This number is the *percent* increase in impedance allowed before an alarm is registered. The usual default limit, 15%, has been chosen as an "early warning" value. In general, replacement of a cell is not necessary at this point, but the situation bears watching. To enter a different limiting percent increase, press the **8** key, followed by two digits. If no alarm for impedance is desired, enter **00**.

Learn INITIAL UNIT IMPEDANCES (9)

Impedance values can be analyzed by either the *average* or *initial* methods. For a discussion of which method to employ, see *Chapter 7 Using the Battery Validation System*. If you decide to use the *average* method, **do not** press the **9** key while the system is unlocked. Pressing the **9** key in the **UNLOCKED MODE** causes two actions - the impedance of each cell or unit is measured and stored, and the *initial* analysis method is permanently invoked. Returning to the average method can be achieved in only two ways: (1) by clearing all memories, which also returns the **BVS** to factory settings, and (2) by starting an initial impedance sequence and then aborting it by pressing the **#** key.

Print LAST AUTO READ DATA (*)

This function does not change system settings but will be described here because it is accessible only in the **UNLOCKED MODE**. The data from the most recent automatically initiated measurement cycle can be printed by pressing the ***** key. First, be sure the printer is turned on.

Exit to NORMAL MODE (#)

Be sure to press the **#** key after settings have been changed. The **uuu** will disappear when the system is re-locked. Should you forget, however, the timeout will return the system to the normal mode after four minutes of inactivity.

Chapter 4 Clearing Memory

Clearing the memory is a multi-step procedure in order to reduce the chance of inadvertently losing data. The power outage data only may be cleared from memory, or nearly everything may be cleared, thereby returning the unit to factory (default) settings. The variables which are *not* cleared are:

- Location Code
- Impedance Multipliers
- Date/Time
- Year
- Load Current Multiplier
- Power Outage Test Interval
- Short Hit Alarm Setting
- Temperature Scale
- Alarm Re-send Interval

First, unlock the system as explained above. Then:

To **CLEAR POWER OUTAGE DATA** only from the reserved portion of memory, press the **A** key once. The system will beep once to indicate that memory is being cleared.

To **CLEAR THE MAIN MEMORY**, press the **B** key ***three times in succession***. This operation will clear *all* memory (except program) and return all settings, except the ones listed above, to their default values. The system will beep three times to indicate that memory is being cleared.

The system will re-lock itself after the clearing routines are finished. Both of these operations may take a minute or so to complete. Please wait until the display returns before pressing another key. After clearing the main memory, it will be necessary to treat the system as if it were being started on the battery for the first time, including learning the cell and long interconnect sequence.

Chapter 5 Using the Diagnostic Mode

The **DIAGNOSTIC MODE** is employed when servicing the battery or the **BVS**. It is also used to set the calendar for leap year and to substitute new "initial" impedance values for old ones in memory following cell replacement. It is entered by pressing **B-B-A-D-C**. The display will show **C 1**.

Setting the Calendar for the YEAR

The **A-D** keys allow selection of a number (which usually represents a cell or unit). The **A** key increments the number by 1; the **B** key increments the number by 10; the **C** key decrements the number by 10; the **D** key decrements the number by 1. After pressing these keys, note that neither the **VOLTS** nor **IMPEDANCE** lights are on.

Using these keys, set the last digit of the current year, as **1** for 2001. Now press the **0** key to make the entry. If the printer is ON, it will show

THE PRESENT YEAR IS 2002

Measuring Individual Parameters

To measure the voltage or impedance of a particular unit, first select that unit using the **A-D** keys. The display will show the number under **UNIT**. To measure voltage, press the **1** key. The display will show the measured voltage with the **VOLTS** light on. To measure impedance, press the **2** key. The display will show the measured impedance with the **IMPEDANCE** light on. You may select another unit and make additional measurements; however, do not make *impedance* measurements more often than once every fifteen seconds.

To replace an initial impedance value with a new one, first select the unit and measure the impedance. Then, with the value still showing, press the **9** key.

To display the temperatures measured by up to four connected thermistors, press any of the keys **3-6**. Pressing the **3** key always displays the ambient temperature. Pressing the other keys will display battery temperatures if thermistors are present. The yellow **TEMPERATURE** light will come on.

Pressing the **7** key makes an "impedance" measurement, but the controlled current flows in the other half of the string in which the chosen unit is located. This type of measurement indicates the percentage of the total controlled current that flows in each half string. Normally, about 55% of the total current flows through the half-string being measured, with the remainder through the other part of the string. In some battery installations long cables and switch poles add extra resistance unsymmetrically. The result is elevated impedance readings overall. When this situation is suspected, the current multipliers (discussed in Chapter 6) can be used to correct the readings. Determine the impedance multipliers using the procedure in the section below. Discuss the situation with **BTECH Inc** before making any changes.

To display the total battery voltage, press the **8** key.

The ***** key causes repeated measurement of the load current when the system is equipped with this option. Press the ***** key again to stop this measurement. This function is only for use with special **BTECH** test equipment.

Press the **#** key when you are finished in this mode. Should you forget, however, the timeout will return the system to the normal mode after four minutes of inactivity.

Determining IMPEDANCE MULTIPLIERS

As discussed earlier, some systems will require an impedance multiplier that is other than 100%. This is easily done by taking advantage of the controlled excitation current and measuring the relative impedances of one (and the same) unit as each of the load circuits is triggered.

- A. Enter the Calibration 1 mode and measure the impedance of any unit in string #1 by pressing the **2** key. Record this value as "Impedance A". After about 15 seconds, press the **7** key and record this value as "Impedance B". Wait about 15 seconds and repeat two more times. Separately average the three values for "Impedance A" and "Impedance B".
- B. Add these two averages together and call the result "Total Impedance".
- C. Calculate the Impedance Multiplier:

$$(\text{Total Impedance} / \text{Impedance A}) \times 50 = \text{Impedance Multiplier \%}$$

Example: Impedance A = 2.37mΩ

$$\text{Impedance B} = 1.03\text{m}\Omega$$

$$\text{Total Impedance} = 2.37 + 1.03 = 3.40\text{m}\Omega$$

$$\text{Impedance Multiplier} = (3.40 / 2.37) \times 50 = 72\%$$

- D. Measurement of one unit in each string should be sufficient to determine the multiplier for both halves of this string. If there are parallel strings, repeat the above procedure with a unit in each string. Enter these values into the program through the **CALIBRATION MODE** as discussed in the following chapter. Measurements reported subsequently will incorporate these multipliers.

Chapter 6 Using the Calibration Mode

The **CALIBRATION MODE** sets some registers in the program involving timing and display of information. It is entered by pressing **B-B-A-D-D**. The display will show **C 2**. The **A-D** keys select values, as above.

Setting **IMPEDANCE MULTIPLIERS (1) (2) (3)**

Battery Validation Systems are delivered with the impedance multipliers set to 100%. This is done because the assumption is made that each cell 'sees' a controlled 11 amperes for the impedance measurement. Depending on the output impedance of the charger, other parallel strings of cells and DC bus wiring and switching, the measurement current may be somewhat higher. For those installations requiring absolute accuracy (as contrasted with relative accuracy), or where some string sections in parallel string batteries exhibit significantly different average impedances not caused by the cells themselves, there is a provision for changing the impedance multiplier to reflect the actual current through the half string.

BTECH urges that you make such changes only after consultation with one of our engineers. However, the procedures for checking and/or entering the impedance multipliers are given below.

If your battery system is a single string, press the **A-D** keys to set the multiplier to **100** or other similar percentage. Then press the **1** key to set the string half to **01**. Pressing the **3** key enters the multiplier for the most positive section of the battery. Make any change needed in the multiplier with the **A-D** keys. Then press the **1** key again to increment the string half to **02**. Finally press the **3** key to enter this multiplier for the negative section of the battery.

If your battery system has parallel strings, each half of each string may use a different impedance multiplier. The half strings are numbered in the sequence shown below. The **1** key increments the half string number and the **2** key decrements the half string number by 1. The **3** key enters the impedance percentage and half string number displayed.

To enter the *same* multiplier for each half string, select the multiplier first. Then select the half string number and press the **3** key. Alternately press the **1** and **3** keys until you reach twice the number of parallel strings. For example, if your battery has five parallel strings, increment the half string number progressively until you reach **10**.

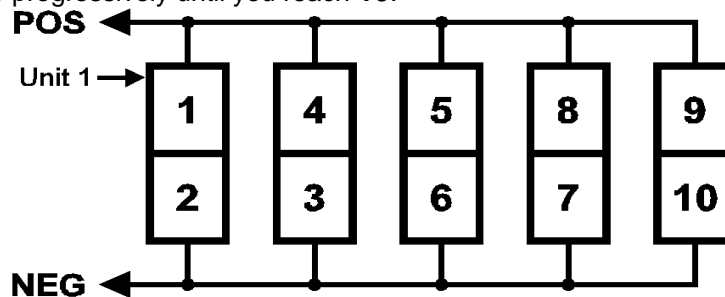

To enter *different* multipliers for each half string, select the multiplier first. Then select the half string number and press the **3** key. Next, select a different multiplier and then a different half string number before pressing the **3** key to enter them. Continue until each variable that you want to

change has been entered. It is not necessary to re-enter those multipliers which are already correct.

The new multipliers will be used the next time a set of impedances is measured. Therefore, to see the effect of the changed multipliers, exit the **CALIBRATION MODE** and request a complete set of readings by pressing the * key. When the read cycle is complete, re-enter this mode and again press the * key. A sample of the printer output is shown below under **CONFIRMING the SETTINGS**.

Setting the LOAD CURRENT MULTIPLIER (4)

During a power outage, the **BVS** will measure the battery discharge current if this optional feature is ordered. To set the **LOAD CURRENT MULTIPLIER**, use the **A-D** keys, as described previously to set the percentage. Then press the **4** key to enter your setting. Use the following table to determine the correct multiplier. If the battery discharge current feature is not included in your **BVS** the **LOAD CURRENT MULTIPLIER** must be set to **0**.

# of Strings	1	2	3	4	5	6	7
Percent of Total Cables Through Clamp	100	50	33.33	25	20	16.67	14.29
Clamp Current Rating	Load Current Multiplier						
200	20*	40	60	80	100	120	140
600	30*	60	90	120	150	180	210
1200	60*	120	180	240	300	360	420
2000	100*	200	300	400	500	600	700
2200	110*	220	330	440	550	660	770
4000	200*	400	600	800			

* Use this Load Current Multiplier regardless of the number of strings only if the clamp is around all cables.

Setting the POWER OUT TEST INTERVAL (5)

During a power outage, a measurement cycle is initiated at regular intervals to capture decreasing cell or unit voltages. The frequency of these measurements is determined by the **POWER OUT TEST INTERVAL**, which is in minutes. Enter a number between 1 and 99 (every 1 or 2 minutes is usual). If you ask for an interval which is too short to allow all the units to be measured, the system will not accept the input (e.g. 240 cells every minute). Use the **A-D** keys, as described previously. Then press the **5** key to enter your setting.

Setting the SHORT HIT ALARM FUNCTION (6)

Some batteries may be subjected to relatively frequent, relatively brief discharges because of the nature of the AC power grid. The **BVS** will generate an alarm for each of these events. Because the situation is normal for these sites, the alarms become a nuisance. The **BVS** incorporates a feature whereby power outage events shorter than 15 seconds will not cause an alarm condition. However, each event still will be instantly *detected and recorded as usual*. **BVS's** as delivered are set to alarm during a hit of less than 15 seconds. Press the **6** key to deactivate this alarm. Pressing it again will activate this alarm. If the printer is ON, it will show:

SHORT HIT ALARM IS ON (or SHORT HIT ALARM IS OFF)

Setting the TEMPERATURE SCALE (7)

The **TEMPERATURE SCALE** default is set to Degrees F. Press the **7** key to set this to Degrees C. Pressing it again will reset to Degrees F. If the printer is ON, it will show:
TEMPERATURE IS IN deg. F (or TEMPERATURE IS IN deg. C)

Setting the ALARM RE-SEND INTERVAL (8)

The **ALARM RE-SEND INTERVAL** is the number of minutes that elapse between the **BVS's** first attempt to transmit an alarm message, and any following attempts. This is useful in an installation where multiple **BVS's** may try to transmit their alarms at the same time to a single PC. It is likely that all the alarms will not be successfully received and a second attempt will be made. Set the intervals on each **BVS** at least 2 minutes apart so that the remaining alarms will go through. The default is 60 minutes and the valid range of settings is 10 - 99. Use the **A-D** keys, as described previously. Then press the **8** key to enter your setting.

Confirming the Settings (*)

Switch on power to the printer and press the ***** key. All of the above settings will be printed. If you wish to make any changes, proceed as described above and again confirm settings on the printer. If all settings are correct, press the **#** key to return to normal operation.

```
AVERAGE IMPEDANCE MODE
# 1 @ 110 % AVG= .69
# 2 @ 95 % AVG= .68
CURRENT FACTOR= 0
POWER OUT INTERVAL= 2
SHORT HIT ALARM IS ON (or OFF)
TEMPERATURE IS IN deg. F (or C)
ALARM ReSEND INTERVAL 60
```

Any changes you make to the default settings are retained in battery-backed RAM and will not be lost by re-booting. But, they will be lost and must be re-entered when the EPROM, computer, or RAM backup battery is disconnected or replaced, or when the **BVS** has been unpowered for a number of months (the NiCad voltage probably has dropped too low to maintain the memory). If in doubt, press the ***** key to print the settings. Re-enter them as necessary.

Chapter 7 Collecting & Analyzing Battery Validation System Data

If the **Battery Validation System** has been correctly installed and programmed, the monitoring is automatic and nothing further need be done with the monitor. Periodic maintenance of the battery according to the manufacturer's directions should be continued however, especially with regard to the watering of flooded cells and the cleanliness and tightness of torqued terminals. Use of a **BVS** does not obviate the need for prudent preventive maintenance, but an alarm should be sent if maintenance procedures are not adequate.ⁱⁱ

Unless operating regulations require it, there should be no need to measure specific gravity or to take the battery off-line for a load test. Increasing cell or unit impedance when interconnects have been eliminated as the cause, will point to deteriorating cell chemistry. Corroborating evidence will be found in the voltage performance of these cells or units during a power outage. Those cells or units with a history of changing impedance before the "hit" will probably also show a faster than average decline in voltage during the "hit."

NORMAL MODE Measurement Data

During a **NORMAL MODE** measurement the data will be displayed and, if the printer is ready, hard copy will be produced. The LED digits will show a **UNIT** identification number and a **VALUE**, and the yellow light will indicate **VOLTS** or **IMPEDANCE**. When showing temperature, a **1** under **UNIT** denotes the ambient temperature, a **2**, the string 1 temperature, a **3**, the string 2 temperature, and a **4**, the string 3 temperature, if in fact there are multiple strings. The yellow temperature light will be on.

The LED displays will appear as shown below; a complete sample printer tape is also shown. Note that the sequence of printed lines in the representations below is reversed from that actually put out by the printer.

1 13.52

LOCATION CODE 78

11/02 17:25

UNIT 1 = 13.52 VOLTS
UNIT 2 = 13.55 VOLTS
UNIT 3 = 13.49 VOLTS
UNIT 4 = 13.61 VOLTS
UNIT 5 = 13.56 VOLTS
UNIT 6 = 13.55 VOLTS
UNIT 7 = 13.54 VOLTS
UNIT 8 = 13.58 VOLTS
UNIT 9 = 13.53 VOLTS
UNIT 10 = 13.63 VOLTS

BATTERY 135 VOLTS

ⁱⁱ BVS is not sensitive to electrolyte level in flooded cells.

AVERAGE IMPEDANCE MODE		(or INITIAL IMPEDANCE MODE)
UNIT	1 =	1.32 mOhms
UNIT	2 =	1.40 mOhms
UNIT	3 =	1.37 mOhms
UNIT	4 =	1.28 mOhms
UNIT	5 =	1.35 mOhms
UNIT	6 =	1.39 mOhms
UNIT	7 =	1.35 mOhms
UNIT	8 =	1.49 mOhms
UNIT	9 =	1.41 mOhms
UNIT	10 =	1.37 mOhms
Therm.	1 =	74 deg.F
Therm.	2 =	75 deg.F
Therm.	3 =	76 deg.F
Therm.	4 =	75 deg.F

Note: BVS will not take impedance readings when the total battery voltage is above or below the permissible float voltage. These measurements are inhibited when the voltage is high because the readings will be influenced by varying conditions of gassing and acid mixing, which may differ from cell to cell and from time to time. When the voltage is low, they are inhibited because the load current regulator may not be able to function properly. The most meaningful readings will be obtained when the battery is in a stable condition on float.

Trending the Data

Trends are much more significant than the magnitude of any single measurement. For trends to be most revealing, several conditions must be observed:

1. Measurements must be taken under the same conditions. The battery should have been on float for at least 48 hours; measurements taken immediately after a "hit" or a load test or an equalize charge may not represent the true state of the cells.
2. Measurements must be taken regularly. Trends are difficult to observe and interpret when the intervals vary widely.
3. There must be a basis on which to compare measurements. Usually this is the cell or jar itself. The voltages and impedances of a number of cells are not identical because, as hard as the manufacturers try, they cannot achieve absolute uniformity.

The **Battery Validation Manager** software has been developed to perform this trending easily and quickly. The voltage of a cell or unit can be graphed with respect to time. The impedance of a cell or unit can be similarly graphed. When the battery is located in a non-temperature controlled environment, then the comparison must be based on the average of the unit impedance measurements made at one time. Analysis under these conditions is more difficult because impedance values are affected inversely by the temperature changes which occur from time to time. Therefore, operating both the monitor and the software in the "initial impedance mode" is to be preferred, *unless* the environment is *not* temperature controlled.

Cell voltage normally will remain quite constant. If there is an upward or downward change which cannot be explained by temperature or charger voltage, for instance, something is happening within the cell. In all likelihood capacity is being affected. Cell voltage which is both acceptable and stable, is a necessary but insufficient condition for good battery performance. In other words, changing cell voltage indicates a problem regardless of impedance values.ⁱⁱⁱ

On the other hand large impedance changes may occur while the voltage remains within acceptable limits and stable. VRLA cells in the early stages of dryout, for instance, perform this way. Therefore, it is necessary to watch trends of both unit voltage and unit impedance and to take corrective action if either one shows a significant change.

Identifying an Impedance Problem

Impedance generally rises very slowly, almost imperceptably, during the life of a lead-acid cell. This change is to be expected. However, when noticeable changes occur over periods of a few weeks to a few months, the degradation rate has accelerated. As stated earlier, a default percent increase of 15% in impedance has been programmed as a generally useful “early warning” alarm value. This degree of “early warning” appears to be adequate for measurements on single and two-cell jars, either flooded or valve regulated. However, three- to six-cell VRLA units may have passed the “early warning” point when the impedance has increased by 15%. Therefore, based upon the criticality of the application, the availability of parallel strings, the economics of the situation, etc., you may wish to set a different “early warning” percentage. In the case of multicell VRLA units, this limit might be 10%. In any case, once the rate of rise in impedance becomes rapid, whether or not the alarm limit has been reached, action should be taken promptly with an urgency commensurate with this rate of rise.

Locating an Impedance Problem

An impedance measurement is always a combination of internal cell parameters and external bolted or clamped interfaces with their associated metallic resistances. The measurement includes every bit of resistance between a pair of voltage sense leads. Whenever a high reading is observed, the question naturally arises - is the problem within the jar where little or nothing can be repaired, or is it external where cleaning and/or re-torqueing the connection will cure it?

The two accessory “pigmy hippo” clips with half fuseholders attached can be used to help resolve this question. Locate the jar which looks suspicious. Attach clips to the two voltage sense leads involved by uncoupling the fuseholders from the leads and re-coupling them to the clips. Now attach the clips directly to the jar posts. Using the **DIAGNOSTIC MODE**, read the impedance. This measurement will represent cell impedance only, rather than cell together with interconnect values. Move the clips so that they span the interconnect, including the bolted surfaces. Take another reading.

Warning: Do not measure impedance more often than once every 15 seconds!

ⁱⁱⁱ This is especially true for NiCad batteries, in which impedance changes are not particularly significant but voltage even under charge is the important measurement to watch.

This measurement represents the interconnect resistance. Move the clips to the same locations as the permanent connections. Take another reading. This measurement should be nearly the same as the value reported after the most recent measurement cycle, and approximately the total of the first two readings. If the problem is not obvious, continue by placing the clips across other nearby jars and interconnects which appear to be good. Comparing readings for jars or readings for interconnects should point to the problem. Note: if the leads will not reach to other jars, use another pair of leads but input the right unit number. See *Using the Diagnostic Mode*.

Very badly degraded cells or interconnects will effect impedance measurements of other units in that string, because they, rather than the **BVS**, will be controlling the load current in that string. Therefore, when there appears to be more than one problem in a string, fix the worst conditions first and then measure again before deciding what other corrective actions to take. A new cell most likely will register a low but slowly rising voltage along with an impedance value different from a stabilized one; ignore them for a few weeks.

POWER OUTAGE DATA

In the event of a power failure and depending on its duration, the **BVS** will store (in battery-backed RAM) data which will show how the battery performed in the emergency. This data includes the date and starting time of the outage to the nearest second, and the same information relating to the return of power. If power went off and on several times, each of these cycles will be noted. If any individual outage was longer than 15 seconds, decaying cell voltages will have been stored. If current was still flowing from the battery after the set **POWER OUT INTERVAL**, a second set of decaying cell voltages will have been stored also. This mode of operation will continue until after the outflow has ceased.

In addition to the cell voltage measurements, the total battery voltage (and optionally, the discharge current) will be recorded once per second during the first 15 seconds of the **POWER OUTAGE**, and at the beginning, and at the $\frac{1}{4}$, $\frac{1}{2}$, $\frac{3}{4}$ points of the **POWER OUT INTERVAL**.

The **PRINT POWER OUTAGE DATA** function will retrieve these measurements after power has returned, cell voltages first, total battery voltages next (and optionally, the discharge currents), then the outage intervals.^{iv} Between the start and finish times of the outage are the immediate optional discharge current and battery voltage measurements. After retrieving the data, it should be cleared from memory unless it is to be permanently archived in the **BVM** software. To clear it, follow the steps in the section on *Clearing Memory* above; *use the A button only*. If the **BVM** software is used to acquire the data over a communications link, the power outage portion of memory may be cleared by the **BVM** software at the conclusion of the data transfer.

One cycle of printed **POWER OUTAGE DATA** will appear as follows:

^{iv} In the unlikely event that the **BVS**' computer re-booted between the power outage and the request for data, a measurement cycle will have to be completed before asking for the power outage data.

```

LOCATION      CODE      78
      11/02      17:25
UNIT 1 = 11.71 VOLTS
UNIT 2 = 11.82 VOLTS
UNIT 3 = 11.94 VOLTS
UNIT 4 = 11.87 VOLTS
UNIT 5 = 11.98 VOLTS
UNIT 6 = 11.89 VOLTS
UNIT 7 = 11.68 VOLTS
UNIT 8 = 11.77 VOLTS
UNIT 9 = 11.88 VOLTS
UNIT 10 = 11.94 VOLTS
LOAD      0      AMPS
BATTERY  118      VOLTS
LOAD      0      AMPS
BATTERY  117      VOLTS
LOAD      0      AMPS
BATTERY  115      VOLTS
LOAD      0      AMPS
BATTERY  114      VOLTS

BATTERY  HIT  INTERVALS

D 11/02      T  17:24:08
LOAD      0      AMPS
BATTERY  120      VOLTS
D 11/02      T  17:28:57

D 11/05      T  22:55:27
LOAD      0      AMPS
BATTERY  120      VOLTS
D 11/05      T  22:55:36

```

Each pair of dates and times above represents a start and finish of one outage. Between the start and finish times of the outage are the immediate optional discharge current and battery voltage measurements. In the example above, there were two hits, the first lasting 4 minutes and 49 seconds, and the second lasting only 9 seconds. During the first hit only, there was time to make one set of unit voltage measurements and four battery measurements. Because the second hit was too brief, no measurements were made.

In the unlikely event that the **BVS** was running on the NiCad battery when its charge gave out during the power failure, there will be voltage readings but both readings in the date/time pair will be the same. Unless the **BVS** is *not* running on protected power *and* the NiCad is faulty, this situation should not occur.

Some users may wish to employ the **BVS** to make cell voltage measurements during an intentional battery load test. Before beginning the test, make sure that the power outage memory is empty so there will be no confusion with data from a previous event. Follow the steps in the Chapter on **Clearing Memory** above. If necessary, change the **POWER-OUT TEST INTERVAL** to relate it to the likely duration of the load test. The entire group of measurements may be dumped to the optional printer or PC *after the test is finished*.

ALARMS

An **ALARM** is registered for an abnormal condition or for a measurement which is outside of allowable limits. Since the alarm indication is a summary one, the user must ask the **BVS** what caused the alarm by pressing the * key *while* the red **ALARM** lamp is lit. The following abnormal operating conditions generate an alarm:

- The computer has ceased to function.
- AC power to the **BVS** has failed.
- Battery has undergone a load.
- The **BVS**' internal NiCad battery is out of limits.
- One or more thermistors are disconnected.
- The **BVS** does not know the cell/interconnection sequence.

The following conditions generate alarms based on measurements outside of *fixed* limits:

- Ambient temperature above 100°F or below 40°F.
- Any battery string temperature more than 15°F above the ambient temperature.

The following conditions generate alarms based on measurements outside of limits which the user may change:

- Total battery voltage is outside of limits.
- An individual cell or unit voltage is outside of limits.
- An individual cell or unit impedance is outside of limits.

Some installations experience frequent, very brief power dips which cause momentary battery discharges. The **BVS** normally will respond to and alarm on all but the very briefest of these events. Should these alarms be a nuisance, **BVS** can be set to register the event but not to send out an alarm when the discharge duration is less than 15 seconds.

Corrective actions, where required, are discussed under **Significance of Lamp Indicators** and **Significance of Failure Messages**. However, voltage and impedance alarms may be avoided in some cases by widening the limits. Since default limits have been calculated from battery manufacturer's published recommendations for preferred float voltage, the user is advised to exercise caution in changing any of the voltage limits. See **Changing System Settings**.

The most desirable situation is receiving stable within-specification-measurements from the **BVS** for many years after it has been installed on a new battery. However, experience suggests that this is not likely to be the case. Eventually, the **ALARM** lamp will come on, or trends in accumulated data will require some remedial action to return the battery to a fully functional backup state. To help determine what action to take *before* the battery becomes unserviceable, see the next section, **Significance of Lamp Indicators** and **Significance of Failure Messages**.

All current data can be recalled locally on the printer or a portable PC running the **Battery Validation Manager**^v software. This data includes the reason for a present alarm, the last automatically read data, initial impedance values (if they were taken), and power outage data if there has been an outage.

^v Some additional data of a supervisory nature is available through the software. See the BVM manual.

Chapter 8 Significance of Lamp Indicators

- Green **MONITOR NORMAL** Light is not illuminated but Red **ALARM** Light is illuminated:

The internal computer is not functioning. Turn the **NICAD** switch off, the **RUN/STANDBY** switch to **STANDBY** and remove AC power. Wait 10 seconds. Re-apply AC power and turn the **NICAD** switch to **ON**. The computer should re-start, showing the correct time on the display. Return the **RUN/STANDBY** switch to **RUN**. All special operating conditions were automatically saved to be available on restart. If a correct time display does not return, the small NiCad battery which backs up the clock and memory must be replaced. This is a user replaceable package. See the section on User Replaceable Spare Parts and the accompanying figure, "REPLACING NICAD BATTERIES". Replacement instructions are given on the figure. After replacing the battery, the system must be treated as if it is being turned on for the first time. All entries such as location code, date, time, and limits if other than the pre-programmed default ones, must be re-entered. See Chapter 3.

- Red **ALARM** light is illuminated along with the green **MONITOR NORMAL** light:

A measurement has reached or passed one of the limits in use, either a default limit or one programmed into the **BVS** by an operator. To view the measurement which caused the alarm, press the * button to display the failure in the window and to print it on the printer. A yellow lamp will come on to indicate the type of measurement, and a unit or cell number and a value will be displayed. In addition, failure data as well as trended data, which will show a deterioration of values leading up to the failure, are available in tabular and graphical format for **BVS** monitors equipped with the optional **Battery Validation Manager** Software program. Press the # **RESET** key only after you are finished reviewing the reasons for the alarm because the system will no longer display the condition which caused an alarm after the **ALARM** light is extinguished.

Note that the keyboard is not active during the time that AC power is unavailable, in order both to conserve internal NiCad battery power and to prevent missing the start of a measurement cycle. Therefore, **BVS** will not display the cause of an alarm until after AC power has returned.

- Yellow **VOLTAGE** light is illuminated

This lamp is illuminated whenever the number being displayed is a voltage. The units are always 'Volts dc' with the decimal point correctly placed.

- Yellow **IMPEDANCE** light is illuminated

This lamp is illuminated whenever the number displayed is an impedance. The units are always 'milliohms'.

- Yellow **TEMPERATURE** light is illuminated.

This lamp is illuminated whenever the number displayed is a temperature. The units are normally °F, but optionally may be specified in °C.

No yellow light is illuminated while time or any number other than a measurement is being displayed.

Date and time are always displayed in that sequence, and a colon separates the first two digits from the second two digits.

Other values may be displayed in response to an operator's keypad inputs; therefore their meanings should be clear. These values include **LOCATION CODE NUMBER, DIAL OUT PHONE NUMBER, AUTO READ INTERVAL**, half string numbers, multipliers, and last two digits of the year.

Chapter 9 Significance of Failure Messages

From time to time, your **BVS** will detect conditions which are other than normal or outside of the limits which it is using. When this happens, in addition to turning on the red alarm light, the LED digits will display the cause and the printer, if turned ON, will put out a FAILURE MESSAGE. These messages are reproduced below, along with descriptions of the "failures" and suggestions for correcting them. Note that successive measurements of the same item may not be absolutely identical.

MESSAGES:

00

or

09:23

FAILURE MESSAGE
LOCATION CODE 78
11/02 09:23
BVS IS UNLEARNED

When the **BVS** is first turned on or after its RAM has been cleared, it needs to establish the sequence of cells and long interconnects in the battery. If you don't initiate this operation with the * key, these printer and display messages will appear: Press the # **RESET** key and then the * **MEASURE** key. After a few seconds, depending on the number of cells in the system, the displays should report, for example:

60 09:23

BVS FOUND 60 UNITS

If it cannot find the correct number of units, the displays will report:

09:45

WRONG AMOUNT OF UNITS
BVS FOUND 39 UNITS
THIS SYSTEM MUST HAVE
60 UNITS
CHECK 43-44, 44-45

MESSAGES:

119

```
FAILURE MESSAGE
LOCATION CODE 78
11/02 09:23
BATTERY 119 VOLTS
```

Whenever the **BVS** finds, on its every-minute check, that the total voltage exceeds the allowable limits, you will see these messages. The condition will have been verified by three consecutive readings. Check the charger; it may be under- or over-charging.

MESSAGES:

1 12.70

```
FAILURE MESSAGE
LOCATION CODE 78
11/02 09:23
UNIT 1 = 12.70 VOLTS
```

When the **BVS** finds, on its cyclic measurement (usually weekly or bi-weekly) that a unit voltage is outside of allowable limits, you will see these messages. They may indicate a degraded unit, or that the charger is supplying too much or too little current relative to the needs of this unit. This message will appear only after a measurement sequence and only after the reading has been verified three consecutive times. Only the first unit in this failure category will be identified; there may be more; scan the tape.

MESSAGES:

21 2.34

```
FAILURE MESSAGE
LOCATION CODE 78
11/02 09:23
UNIT 21 = 2.34 mOhms
FAILED AVERAGE OF 1.69
```

When the **BVS** finds, on its cyclic measurement (usually weekly or bi-weekly) that a unit is exhibiting an impedance which is more than the allowed percentage above the average impedance of all the units, you will see these messages. Depending on the degree by which the limit has been exceeded or the existence of a trend, prompt action may be advisable, or continued close surveillance could be adequate for now. This message will appear only after a measurement sequence and only after the reading has been verified three consecutive times. Only the first unit in this failure category will be identified; there may be more; scan the tape.

MESSAGES:

21 2.34

```
FAILURE MESSAGE
LOCATION CODE 78
11/02 09:23
UNIT 21 = 2.34 mOhms
FAILED INITIAL OF 1.69
```

When the **BVS** finds, on its cyclic measurement (usually weekly or bi-weekly) that a unit is exhibiting an impedance which is more than the allowed percentage above the initial impedance of this same unit, you will see these messages. Depending on the degree by which the limit has been exceeded or the existence of a trend, prompt action may be advisable, or continued close surveillance could be adequate for now. This message will appear only after a measurement sequence and only after the reading has been verified three consecutive times. Only the first unit in this failure category will be identified; there may be more; scan the tape.

MESSAGES:

3 99

```
fFAILURE MESSAGE
LOCATION CODE 78
11/02 09:23
DIF.TEMP. T 3 = 90 deg.F
```

Whenever the **BVS** finds, on its every-minute check, that the temperature indicated by one of the battery's thermistors is above the ambient temperature by more than 15°F, you will see these messages. They will appear only when the *difference* is greater than 15°F. If the battery is made up of valve-regulated cells, thermal runaway may be imminent. The charger should be shut off while the problem is being diagnosed and corrected. Improved ventilation may be helpful. In any event, the battery manufacturer's directions should be followed. This condition is potentially dangerous; corrective action should be undertaken without delay!

MESSAGES:

4	00
---	----

```
FAILURE MESSAGE
LOCATION CODE 78
11/02 09:23
Therm. 4 NO READ
```

Whenever the **BVS** finds, on its every-minute check, that a thermistor is not connected as it should be, you will see these messages. The likely cause is a faulty 6-pin connector on the chassis or a broken or disconnected lead. Therm 4 is connected between pins 5 & 6. The problem should be remedied promptly, since there will be no monitoring of this critical parameter in string 3 (in this case) until the thermistor circuit is repaired.

MESSAGES:

1	105
---	-----

```
FAILURE MESSAGE
LOCATION CODE 78
11/02 09:23
Therm. 1 = 105 deg.F
```

Whenever the **BVS** finds, on its every-minute check, that the ambient temperature is beyond the fixed limits of 40-100°F, you will see these messages. If the space is temperature-controlled, the system probably has failed; if the space is not temperature-controlled, battery life will be reduced if the temperature is high or output will be reduced if the temperature is low. The problem should be remedied promptly if possible.

MESSAGES:

999	9999
-----	------

```
FAILURE MESSAGE
LOCATION CODE 78
11/02 09:23
BATTERY TOOK HIT(s)
```

These messages will appear after the system returns to normal operation following a power outage. Press the **A** key to **PRINT POWER OUTAGE DATA**.

MESSAGES:

888	8888
------------	-------------

```
FAILURE MESSAGE
LOCATION CODE 78
11/02 09:23
AC POWER FAILURE
```

These messages will appear after the system returns to normal operation following an AC power input failure not accompanied by a battery hit.

MESSAGES:

CC CC

```
FAILURE MESSAGE
LOCATION CODE 78
11/02 09:23
NICAD OUT OF LIMITS
```

When the **BVS** finds, on its cyclic measurement (usually weekly or bi-weekly) that its back-up NiCad battery is not charging correctly, you will see these messages. Measure the terminal voltage of the NiCad (see the service manual); it probably needs to be replaced. The figure, "REPLACING NICAD BATTERIES", includes instructions for exchanging this battery.

One failure message tape may contain multiple categories of failures. It is important to note, however, that should there be several unit voltage failures, only the first one will be printed; if there are several unit impedance failures, only the first one will be printed on the tape. After repairing the noted items, scan the complete set of data looking for more units which may have failed for voltage or impedance.

All data sent to the optional printer may also be sent to a PC (furnished by the user) running the **BVM** Software. This data is identical in format. Whether you trend the data manually or with the **BVM** software, historical data will allow you to observe gradual deterioration in cells or interconnects, drift in charger voltage, and so on.

Chapter 10 Customer Support

USER REPLACEABLE SPARE PARTS

Item	Part Number
Backup Operating Battery	4200001.0
RAM Backup Battery	4200002.0
Printer Ribbon Cassette (Epson ERC-09)	4600001.0
Printer Paper (std. NCR 2¼" #997003)	4600002.0
Fuse: 9 amp. Fast-acting, KTK-9 (Current Control)	8800009.0
Fuse: 1/16 amp AGC (In-line fuseholder)	8800116.0

Note: The above listed parts may be ordered directly from **BTECH Inc.** using the part numbers given or from local sources using the referenced manufacturer's part number. Call for current prices. See the figure, "REPLACING NICAD BATTERIES", for instructions on where these batteries are located and how to replace them.

TECHNICAL SUPPORT

If a modem is included in this **BVS**, this product complies with Part 68 of the FCC rules and regulations. With each device shipped, there is a label which contains among other information, the FCC Registration number and Ringer Equivalence Number (REN) for this product. You must, upon request, provide this information to your telephone company.

The REN is useful to determine the number of devices you may connect to a telephone line and still have all of these devices ring when the number is called. In most, but not all areas, the sum of the RENs of all of the devices connected to one line should not exceed five. To be certain of the number of devices you may connect to the line, as determined by the REN, you should contact the local telephone company to determine the maximum REN for your calling area.

If your system causes harm to the telephone network, the telephone company may discontinue service temporarily. If possible, they will notify you in advance. If advance notification is not practical, you will be notified as soon as possible. Your telephone company may make changes in its facilities, equipment, operations or procedures that could affect proper functioning of your equipment. If they do, you will be notified in advance to give you an opportunity to maintain uninterrupted telephone service.

The device may not be used on coin service lines provided by the telephone company (this does not apply to private coin telephone applications which use standard telephone lines). Connection to party lines is subject to state tariffs.

If you experience trouble with this device, please contact **BTECH Inc.** for information on obtaining service or repairs. The telephone company may ask you to disconnect this device from the network until the problem has been corrected or until you are sure that the device is not malfunctioning.

BTECH Inc.
10 Astro Place
Rockaway, NJ 07866

(973) 983-1120 (Main)
(973) 983-1125 (FAX)
Web site: www.btechinc.com
Email: techsupport@btechinc.com



PRODUCT WARRANTY

BATTERY VALIDATION SYSTEM Model BVS S3-XXX

BTECH Battery Validation Systems are warranted against defective materials and workmanship for a period of one year from date of delivery to the original purchaser. Any product that is found to be defective within the warranty period will, at BTECH's option, be repaired or replaced without charge when received by BTECH, shipping prepaid.

During the warranty period, BTECH or an authorized service organization will provide warranty service under the type of service required for the monitor and will manage and install engineering changes that apply to the monitor. BTECH or the authorized service organization will specify the type and extent of service.

Replacement parts assume the remaining warranty of the parts they replace.

This warranty does not apply to products which have been altered or repaired by other than BTECH or an approved BTECH service organization, nor to ones which have been subject to misuse, accident, unsuitable physical or operating environment, or improper maintenance by you, or failure caused by a product for which BTECH is not responsible.

These warranties replace all other warranties, express or implied, including, but not limited to the implied warranties of fitness for a particular purpose. However, some laws do not allow the exclusion of implied warranties. If these laws apply, then all express and implied warranties are limited to the warranty period. No warranties apply after that period.

Some jurisdictions do not allow limitations on how long an implied warranty lasts, so the above limitation may not apply to you.

An optional extended warranty is available. This option extends the warranty an additional period of one or more years from date of delivery.

Shipping costs to and from the factory must be paid by the purchaser and are not covered under this warranty.

To obtain warranty service, you should contact your reseller or call BTECH. The BTECH main number is (973) 983-1120.

BTECH Battery Validation System

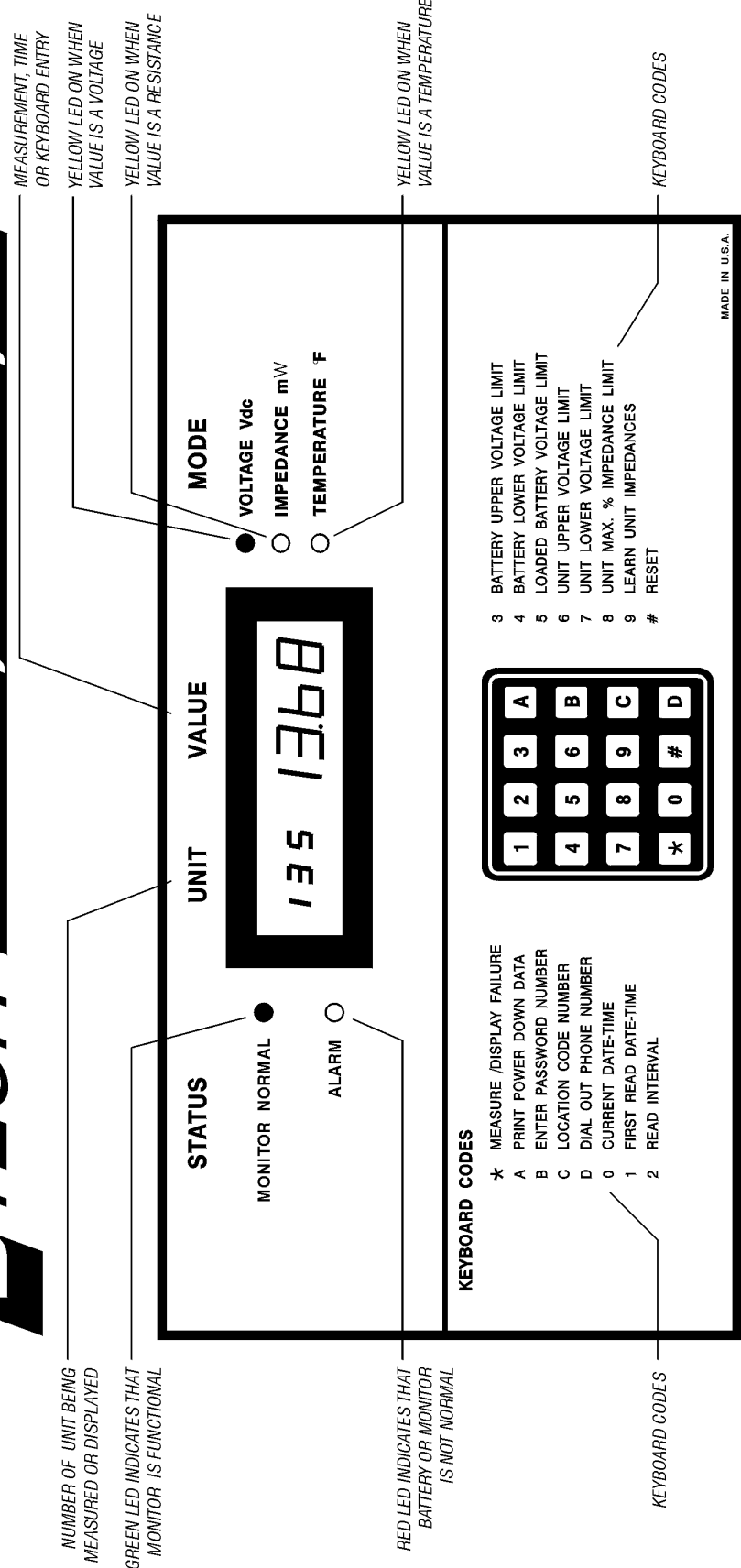

BATTERY VALIDATION SYSTEM MODEL S3 FRONT PANEL INPUTS AND DISPLAYS

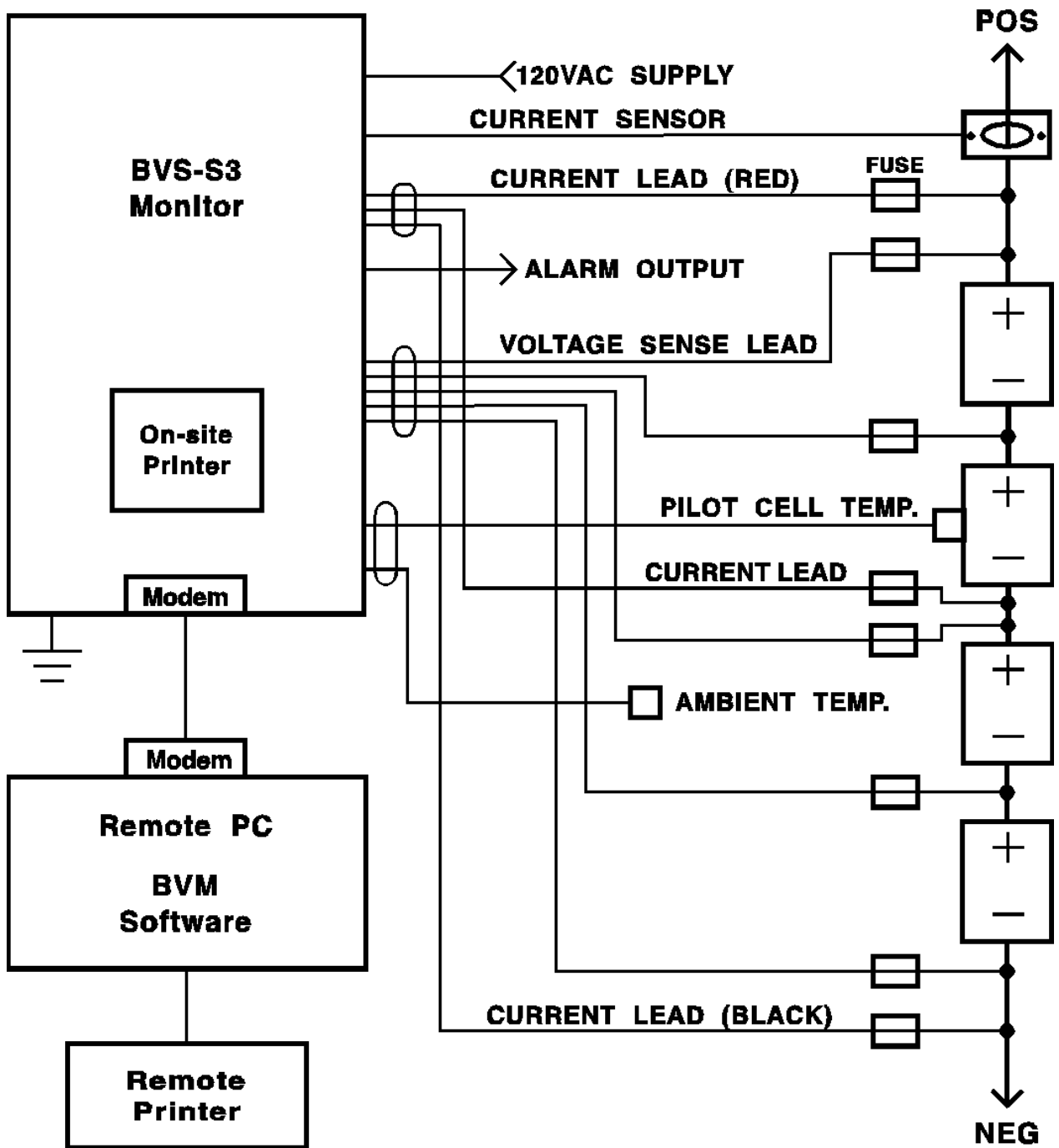

BATTERY VALIDATION SYSTEM MODEL S3

SYSTEM DIAGRAM

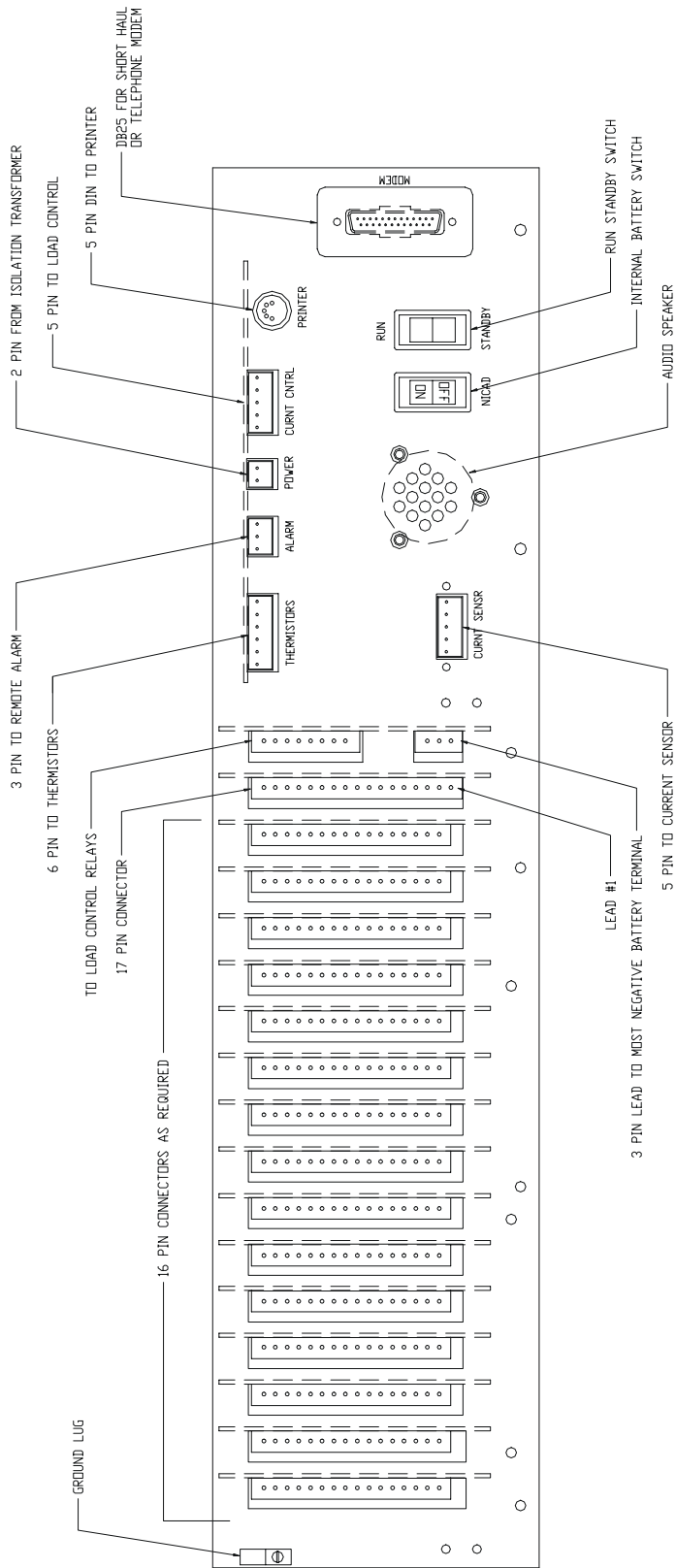

CONNLOC.DWG
REV. 1.10/25/96

INTERNAL CONNECTOR LOCATIONS

CAUTION - REMOVE ONLY THE SCREWS HOLDING THE COVER
 REMOVE 5 SCREWS ALONG THIS
 EDGE TO REMOVE INNER COVER

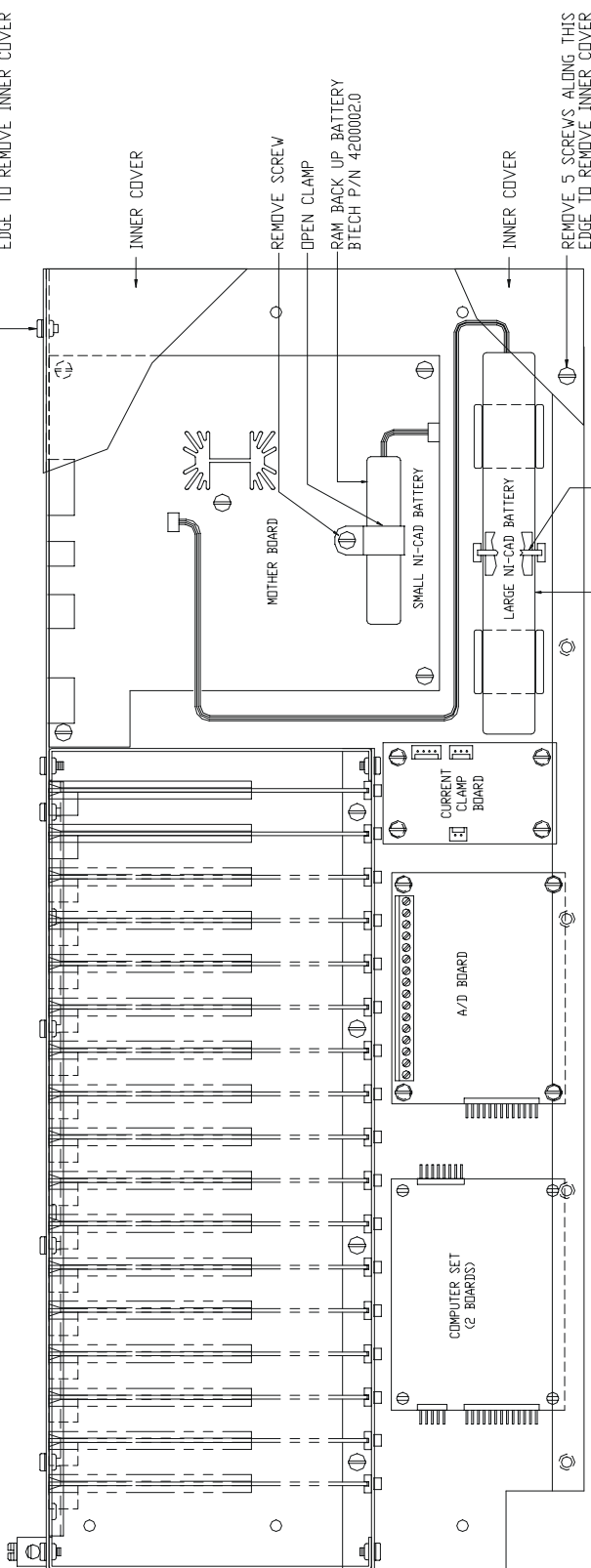

INNER COVER

REMOVE SCREW

OPEN CLAMP
 RAM BACK UP BATTERY
 BTECH P/N 4200020

INNER COVER

REMOVE 5 SCREWS ALONG THIS
 EDGE TO REMOVE INNER COVER

BACK UP OPERATING BATTERY
 BTECH P/N 4200010

CUT TY-WRAP HOLDING BATTERY
 THIS TY-WRAP IS FOR SHIPPING PURPOSE
 ONLY AND NEED NOT BE REPLACED.

REPLACING NICAD BATTERIES

NICADREPL.DWG